

**PROCUREMENT SECTION**

**INDIGENOUS ENQUIRY**

M/s.

Ref. No.:

LHE-20118

Date:

30.10.2013

Due Date:

11.11.2013

Dear Sirs,

We require the following items for XXXIII - Indian Antarctic Expedition. You are requested to send your offer for the following items as per the terms and conditions mentioned below.

SL. NO.	ITEM DESCRIPTION	QUANTITY
01.	Rockbreaker with working spares ( detailed specifications and drawings as per Annexure-I & II)	As per Annexure-I

Your offer should contain the following information:

1. Validity period
2. Quantity / Trade discounts, if any.
3. Delivery Schedules.
4. Terms of Price.
5. Mode of Despatch.
6. Taxes/VAT applicable with Full Rate/Percentage ('C' / 'D' form not available).
7. Indicate if Excise Duty included or extra and Rate/Not Applicable.
8. Guarantee / Warrantee:
9. Please specify Brand/Make Model of the items:

NOTE: Please enclose a copy of valid Authorized Dealership/Distributor Certificate failing which tender will be rejected.

Also confirm that "the rates quoted by you are reasonable and lowest charged to any of your customer".

Please submit your quotation strictly as per the format given in Annexure-II.

Yours faithfully,

Sd/-

Executive (Procurement)  
For and on behalf of Director, NCAOR

SR. NO.	NAME OF ITEM		QTY.	BRAND/MAKE	UNIT OF MEASUREMENT	Unit RATE (₹)	DISCOUNT	Unit rate after discount	TAXES / VAT	Unit rate after discount with taxes/VAT	AMOUNT (₹)
1	2		3	4	5	6	7	8	9	10	11*
	Farukawa										
01.	F6 - XP	F6 Rockbreaker with working spares	01 nos								
02.	F6 - 25114	Point, Wedge	01 nos								
03.	F6 - 25116	Rod, Ballpoint	01 nos								
04.	086705-19040	Hose, Oil (L400)	01 nos								
05.	HB20G 92105	Cylinder, Nitrogen Gas	02 nos								
06.	086725-19120	Hose, Oil (L1200)	01 nos								
07.	084807-06000	Connector, Elbow	01 nos								
08.	084899-06000	Plug, Holes	01 nos								
09	086725-19170	Hose, oil (L1700)	01 nos								
10.	084899-06000	Plug, Hose	01 nos								
		Maintenance manual	01 nos								
		Spare parts Manual	01 nos								

\* Amount in column no. 11 to be mentioned multiplying the quantity with unit rate arrived at column no. 10 i.e. after discount and taxes if any (column 3 x column 10).

(RUPEES.....)

Signature:

Date:

Seal:

Note: 1. Please submit your rates for the items exactly as per the format by providing the necessary details in each column duly signed and sealed.

2. Quotations should preferably be typed and without any corrections and over writings.

Bidders that doesn't manufacture the goods it offers to supply shall submit Manufacturer's Authorization form on the letterhead of the Manufacturer duly signed and stamped by a person with the proper authority to sign documents that are binding on the Manufacturer as per the following format should be submitted failing which the quotation will not be considered.

To  
The Director  
NCAOR  
GOA

Sub: Manufacturers' Authorization form against Tender No: \_\_\_\_\_

We \_\_\_\_\_ (Name of the Manufacturer) who are official manufacturers of \_\_\_\_\_ (Type of goods manufactured) having factories at \_\_\_\_\_ (full address of Manufacturer's factories) do hereby authorize \_\_\_\_\_ ( Name of the Bidder) to submit a bid against your Tender No. \_\_\_\_\_ for the \_\_\_\_\_ Goods manufactured by us and to subsequently negotiate and sign the contract.

We hereby extend our full guarantee and warranty with respect to the Goods offered by the above firm

Manufacturer's Name:  
Signature of Authorized  
representative of the Manufacturer:

Duly authorized to sign this Authorization on behalf of : \_\_\_\_\_ (Name of the Bidder)

Date:

# EXTERNAL DIMENSIONS

## External dimensions of hydraulic breaker

F6

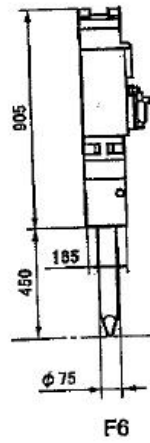

## External dimensions of side bracket (Set plate type)

F6

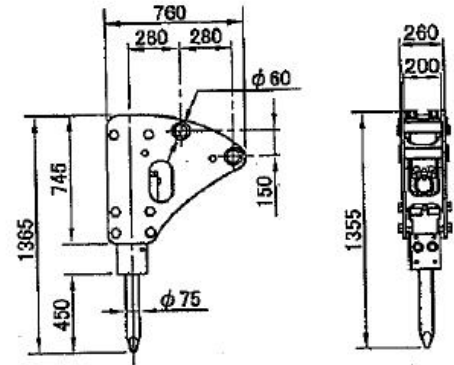

Distance between pins: 318mm

## External dimensions of T-box

Top bracket is not included in the assembly.

F6

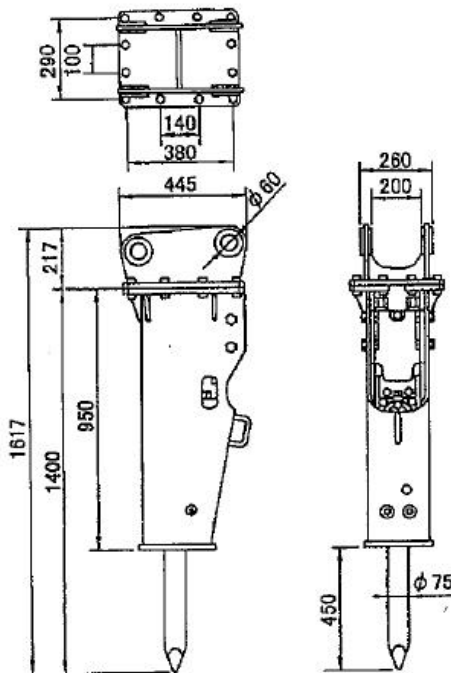

Distance between pins: 326mm

## External dimensions of Side plate

Top bracket is not included in the assembly.

F6

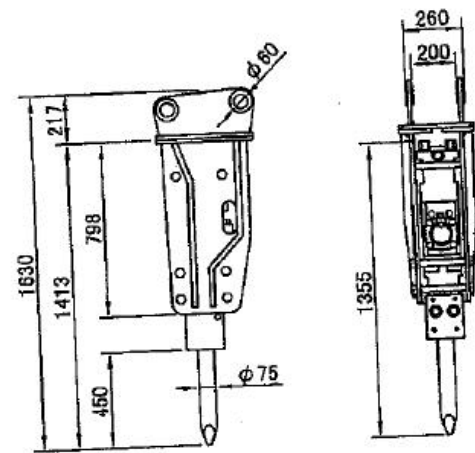

Distance between pins: 326mm

T-box  
F6

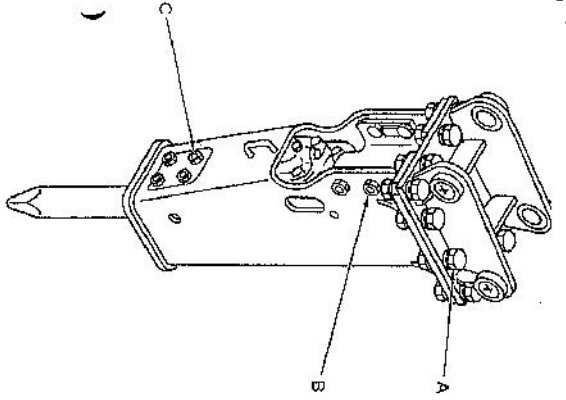

Location	Model
	F6
A Top bracket	Bolt size M20x1.5 HEX head size 30 Tightening torque 450
B Spacer	Bolt size M24x3.0 HEX head size 36 Tightening torque 600
C Pin cover	Bolt size — HEX socket size — Tightening torque N-m

- A: Top bracket
- B: Spacer
- C: Pin cover

Side plate  
F6

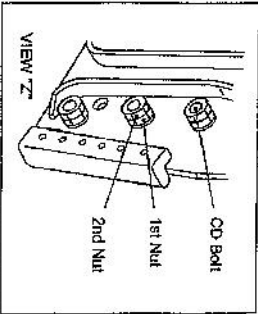
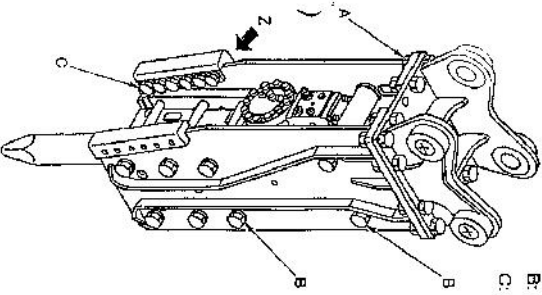

- A: Top bracket
- B: CD bolt
- C: Guard

Location	Model
	F6
A Top bracket	Bolt size M20x1.5 HEX head size 30 Tightening torque 450
B CD bolt	Bolt size M27x2.0 HEX head size 41 Tightening torque 900
C Guard	Bolt size — HEX head size — Nut HEX size — Tightening torque N-m

**Tightening torque of each bolt Breaker main body**  
**F6**

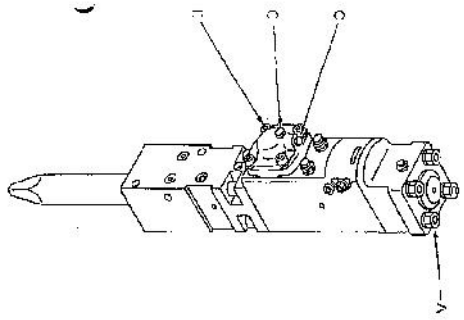

Location	Model
	F6
M27x2.0	
Bolt size	mm 14
HEX socket size	mm 14
A Through bolt	
Nut HEX size	mm 41
Tightening torque	N·m 900
M16x1.5	
B Accumulator	
Bolt size	mm 14
HEX socket size	N·m 250
Tightening torque	
C Accumulator cap, plug	
HEX head size	mm 22
Tightening torque	N·m 150

- A: Through bolt
- B: Accumulator
- C: Accumulator cap/plug

**Side bracket (Set plate type)**  
**F6**

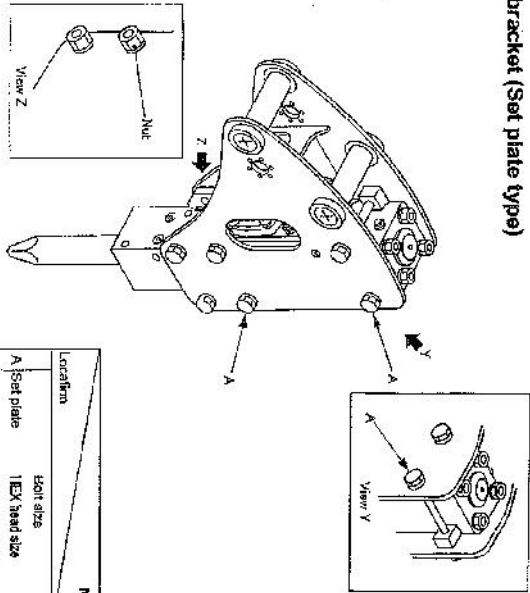

Location	Model
	F6
M27x3.0	
A Set plate	
Bolt size	mm 41
HEX head size	N·m 900
Tightening torque	

A: Set plate

PURCHASE ENQUIRY – GENERAL TERMS AND CONDITIONS

1. This quotation and any order resulting from this Enquiry shall be governed by Terms and Conditions mentioned in this enquiry.
2. Where counter terms and conditions of business have been offered by this supplier, we shall not be deemed to be governed by these unless our specific written/ acceptance there of has been given.
3. No conditions and terms notice of which has not been given by the Supplier while submitting quotation will be considered by us if put forward in subsequent correspondence.
4. Quotation : Quotation should be submitted in a envelope super scribed with Enquiry Number and Due Date and the same must reach our office on or before the Due Date by 17.30 hrs (IST).
5. Specifications : Materials should be offered strictly conforming to our specification. The deviation in specification if any should be clearly indicated by the supplier in his quotation. The supplier should also indicate make/type No. of the materials offered. Vague terms such as Best Indian, Best Indigenous. Imported Make should not be used.
6. The rate quoted against each should be in units stated in the Enquiry. Where quotations are in terms of units other than those specified, relationship between the two sets of units must be furnished.
7. Samples : Samples where asked for shall be submitted, free of all charges and should reach us before the Due Date of the Enquiry. Sample must be carefully packed and labelled clearly with enquiry No. & due date. We shall not be responsible in any way for the loss or damage of samples due to any reasons whatsoever. In the event of the non-acceptance of offer, supplier will have to remove the samples at his own expenses.
8. Terms of prices : Quotation should be submitted on F.O.R. Vasco or F.O.R. Destination price including transit Insurance. Preference will be given to such quotations. For quotations Ex-Works, Ex-godown/F.O.R. Despatching Station, the approximate packing, forwarding & freight should be indicated by the supplier. Quotations from Local Suppliers should be delivered at our stores.
9. Validity : The quotation should remain valid for a minimum period of 90 days from the Due Date of the Enquiry.
10. Sales Tax : NCAOR is not entitled to issue Form C or D. No Sales Tax or any other tax shall be payable by us unless payment of the same is specifically mentioned by the suppliers in their quotation and same is legally leviable.
11. NCAOR is exempted from payment of Excise duty / Custom duty as per Government notification hence the rate should be split into Basic Cost and Excise Duty, if any.
12. Duties / Taxes : Approximate percentage to be charged should be clearly mentioned in the quotation.
13. Insurance : The supplier will be responsible for and should cover, the insurance for all transit risks if the terms of prices are F.O.R. Vasco or F.O.R. Destination unless otherwise stated specifically by the supplier in his quotation.
14. Delivery : Preference will be given to Ex-Stock offers Suppliers submitting quotation on forward delivery basis must indicate earliest firm delivery date by which the materials will be despatched by them from the date of receipt of order. Offer such as "Ex-stock Subject to prior Sale" or "Delivery at the earliest" may not be entertained.
15. Inspection : Material on its arrival at our site will be inspected by our Inspection Department and their decision in the matter will be considered final and binding on the Supplier.
16. Payment : Payment for accepted quantity will be made as agreed to while placing order. Discount, Rebate, if any, for early Payment should be clearly stated.
17. Director NCAOR reserves the right to reject any or all the offers received or to accept any offer wholly or in a part of order of a lesser quantity without assigning any reason. The tenders shall be bounded to execute such an order.
18. In case the supplier does not deliver the goods according to the delivery schedule, he will be liable to pay 0.5% of the value of the goods not delivered according to schedule, as liquidated damages for delay of week or party thereof subject to maximum 5% of the value of goods not delivered, without prejudice to the right of NCAOR
19. In case an order placed by the NCAOR based on the quotation submitted by the supplier is not executed by him, the NCAOR may buy the ordered goods from elsewhere and recover, the additional amount if may have to spend in procuring the stores plus 10% to cover the incidental expenses.
20. All disputes arising in connection with executing the purchase order will be subject to the Jurisdiction of the Courts in Goa only.

Sd/-  
Executive (Procurement)  
For and on behalf of Director, NCAOR